

三代升级款数控升降压电源

型号: ZK-SK150Pro

产品参数

产品名称: 数控直流升降压电源

输入电压: 7-36.00V

输出电流: 0-8.000A

输出功率: 150W

电压分辨率: 0.01V

数据组存储: 11组

屏幕尺寸: 1.8寸升级大屏, 36*29mm可视范围

转换效率: 88%左右

产品尺寸: 83x48x48mm (高度不含旋转编码器)

产品重量: 净重112g, 含包装重132g

保护机制:

输入防反接: 有 输出防倒灌: 有

输入欠压保护(LUP): 6.0-40V可调, 出厂默认值6.0V

输出过压保护(OUP): 0.5-42V可调, 出厂默认值42V

输出过流保护(OCP): 0.001-8.2A可调, 出厂默认值8.2A

输出过功率保护(OPP): 0.1-180W可调, 出厂默认值160W

过温保护(OTP): 30-150°C可调, 出厂默认值100°C

超时保护(OHP): 1分钟-99小时59分钟, 出厂默认关闭

超容量保护(OAH): 0.001-9999Ah, 出厂默认关闭

超能量保护(OPH): 0.001-4000KWh, 出厂默认关闭

产品型号: ZK-SK150Pro

输出电压: 0.5-40.00V

输出电压精度: $\pm 0.3\%$ +3个字 (可校准)

输出电流精度: $\pm 0.5\%$ +3个字 (可校准)

电流分辨率: 0.001A

硅胶按键: 5个

蜂鸣器: 有

软启动: 有

按键功能

短按: 切换输入电压/输出电压显示

长按: 进入或退出设置菜单

短按: 选择位 (设置菜单界面)

长按: 打开/取消锁定功能

左旋转: 数字减

右旋转: 数字加



短按: 切换输出功率W/容量Ah/能量Wh/时间h/温度°C / 轮显

短按: 关闭/打开输出
长按: 休眠关机

显示界面

IN: 输入电压 — IN 18.0 CV V

OUT: 输出电压

OUT 24.00 CV V — 恒压显示CV
1.108 A — 输出电压
026.6 W — 输出电流
也可轮显

ON: 输出开启状态;
电源按键灯亮

OFF: 输出关断状态;
电源按键灯灭

ON 026.6 W — 功率W

ON 0026 Ah — 容量Ah

ON 0522 Wh — 能量Wh

ON 00:03 h — 时间h

ON 31°C — 温度°C

OUT 00.10 V — 恒流显示CC
2.000 A
ON 00.20 W

蜂鸣器打开 锁定功能打开
设置 SET 定时功能打开

产品尺寸



建议开口尺寸

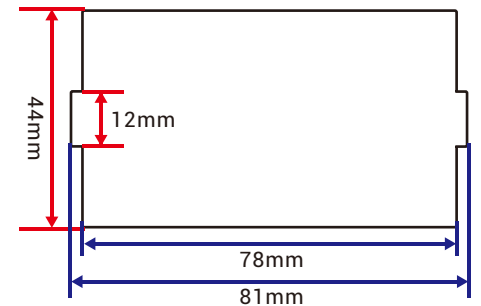

使用说明

设置电压/调用数据组



按 **V-SET** 进入电压设置界面，调整位闪烁，按编码器可选择位，旋转调整大小。设置好后，再按 **V-SET** 一下，退出设置。

按 **OK/↓** 切换数据组Cd00-Cd10。



按 **I-SET** 进入电流设置界面，调整位闪烁，按编码器可选择位，旋转调整大小。设置好后，再按 **I-SET** 一下，退出设置。

按 **OK/↓** 切换数据组Cd00-Cd10。

切换输出/输入电压显示



按 **M/↑** 切换输出电压/输入电压显示

切换输出功率/容量等显示



按 **OK/↓** 切换输出功率W/
容量Ah/能量Wh/
时间h/温度°C /轮显

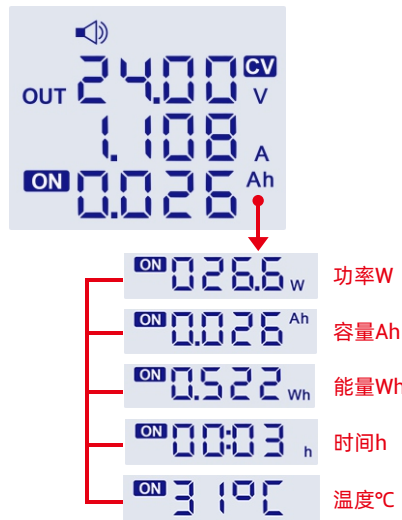

锁定功能

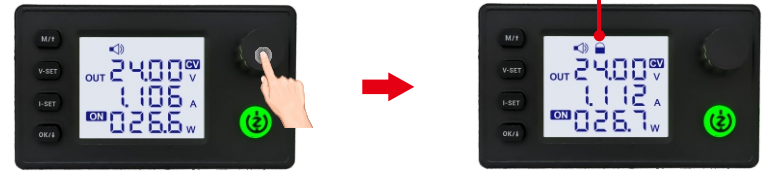

在正常显示界面，长按旋转编码器2秒，锁定设置的电压与电流，防止误操作；锁定后长按编码器2秒解锁。

锁定后电源键一样能够正常操作，确保随时可以断开电源。

参数设置

长按 **M/↑** 2秒进入设置菜单，第一个界面为OUP设置界面，按 **V-SET** 切换数据组名，

按 **I-SET** 选择上一个参数，按 **OK/↓** 选择下一个参数。

数据组内的参数设置

OUP设置（过压保护）



短按编码器选择位，通过旋转调整数值大小。

比如OUP设置为24.00，当输出电压大于24.00V时，输出会关断保护，从而保护负载不会因超压供电烧坏。保护后最下方一行会显示OUP，按电源键取消保护。

OCP设置（过流保护）



短按编码器选择位，通过旋转调整数值大小。

比如OCP设置为2.000，当输出电流大于2.000A时，输出会关断保护，从而保护负载不会因过流烧坏。保护后最下方一行会显示OCP，按电源键取消保护。

LUP设置（欠压保护）



短按编码器选择位，通过旋转调整数值大小。

比如LUP设置为10.00，当输入电压低于10.00V时，输出会关断保护。保护后最下方一行会显示LUP，按电源键取消保护，或输入电压高于LUP时自动取消保护。

OPP设置（过功率保护）



短按编码器选择位，通过旋转调整数值大小。

比如OPP设置为30.00W，当输出功率高于30.00W时，输出会关断保护，从而保护负载不会因过功率烧坏。保护后最下方一行会显示OPP，按电源键取消保护。

OAH设置（超容量保护）



短按电源键开启/关断超容量保护功能，----为此功能关断

按电源键打开此功能后，短按编码器选择位，通过旋转调整数值大小，长按电源键可切换小数点位置（0.000Ah，00.00Ah，000.0Ah，0000Ah），最大可设置为9999Ah。比如OAH设置为1.000Ah，当输出累计容量大于1.000Ah时，输出会关断保护。保护后最下方一行会显示OAH，按电源键取消保护，并且累计容量清零。

<p>OPH设置（超能量保护）</p> 	<p>短按电源键开启/关断超能量保护功能，----为此功能关断</p> <p>按电源键打开此功能后，短按编码器选择位，通过旋转调整数值大小，长按电源键可切换小数点位置[0.000Wh, 00.00Wh, 000.0Wh, 0000Wh, 0.0.0.0Wh（代表0000KWh）]，最大可设置为4000KWh。比如OPH设置为100.0Wh，当输出累计能量大于100.0Wh时，输出会关断保护。</p> <p>保护后最下方一行会显示OPH，按电源键取消保护，并且累计能量清零。</p>
<p>OHP设置（超时间保护）</p> 	<p>短按电源键开启/关断超时间保护功能，----为此功能关断</p> <p>按电源键打开此功能后，短按编码器选择位，通过旋转调整数值大小，最小单位是1分钟，最大可设为99小时59分钟。比如OHP设置为02:30，当开机时间超过2小时30分钟时，输出会关断保护。</p> <p>保护后最下方一行会显示OHP，按电源键取消保护，并且开机时间清零。</p>
<p>OTP设置（过温保护）</p> 	<p>短按编码器选择位，通过旋转调整数值大小，单位°C</p> <p>比如OTP设置为90°C，当功率管附近PCB温度达到90°C时，输出会关断保护。</p> <p>保护后最下方一行会显示OTP，按电源键取消保护。</p>
<p>PON设置（默认上电输出）</p> 	<p>短按电源键，选择上电后输出关断/开启</p> <p>比如设置PON为OFF，那么每次模块刚上电时输出是关断状态，需按一下电源键开启输出；否则，模块上电后输出直接打开。</p>

系统参数设置

<p>Add设置（地址）</p> 	<p>短按编码器选择位，通过旋转调整数值大小</p> <p>地址范围001-255</p>
<p>LEd设置（背光亮度）</p> 	<p>通过旋转调整数值大小，0-5级，0为完全关断背光。</p> <p>出厂默认为5级最亮。</p>
<p>SLP设置（自动熄屏）</p> 	<p>短按电源键开启/关断无操作熄屏（仅关断背光）功能，----为此功能关断</p> <p>按电源键打开此功能后，短按编码器选择位，通过旋转调整数值大小，1-60分钟。比如SLP设置为01，当无操作时间超过1分钟自动熄屏。</p>
<p>bEEP设置（蜂鸣器使能）</p> 	<p>短按电源键打开/关断蜂鸣器</p> <p>比如显示OFF，蜂鸣器被关断不再有按键和报警提示音。</p>

<p>Zero设置（电流零点校准）</p> 	<p>如果输出不接负载有200mA以内的小电流，可以短按电源键，校准零点。校准零点时，输出端不要接负载。</p>
<p>Frd设置（恢复出厂设置）</p> 	<p>可以长按电源键，Frd不闪烁恢复出厂默认。</p>
<p>CAL_U设置（校准输出电压）</p> 	<p>如果输出电压不准，可以校准输出电压。</p> <ol style="list-style-type: none"> 短按电源键，第二行显示01步，第一行电压显示数字闪烁，短按旋转编码器可以移位。 用万用表测量现在输出端（输出端空载，测量电源端子）实际电压，输入到第一行。 短按电源键，第二行显示02步。 用万用表再次测量现在输出端实际电压，输入到第一行。 短按电源键，完成校准。 <p>如果校准成功，第二行显SUC，否则显示Err。如果失败可尝试再次校准。</p>
<p>CAL_I设置（校准输出电流）</p> 	<p>如果输出电流不准，可以校准输出电流。</p> <ol style="list-style-type: none"> 短按电源键，第一行显示01步，第二行电流显示数字闪烁，短按旋转编码器可以移位。 用万用表电流档或用电子负载，短接输出两端测量现在实际电流，输入到第二行。 短按电源键，第一行显示02步。 用万用表再次测量现在输出端实际电流，输入到第二行。 短按电源键，完成校准。 <p>如果校准成功，第二行显SUC，否则显示Err。如果失败可尝试再次校准。</p>

APP联机方法



- ① 电源主板通信接口插入ZK-BT蓝牙板，插入瞬间ZK-BT指示灯会闪一下。
- ② 打开无治智联APP和手机蓝牙，APP界面点击“添加设备”，会自动搜索到Wuzhi Power，点击后自动连接。
- ③ 显示连接成功，点击完成。
- ④ 点击设备图标，进入正常操作界面，长按产品图标可更改名字或删除设备。



下载电源APP

上位机联机方法

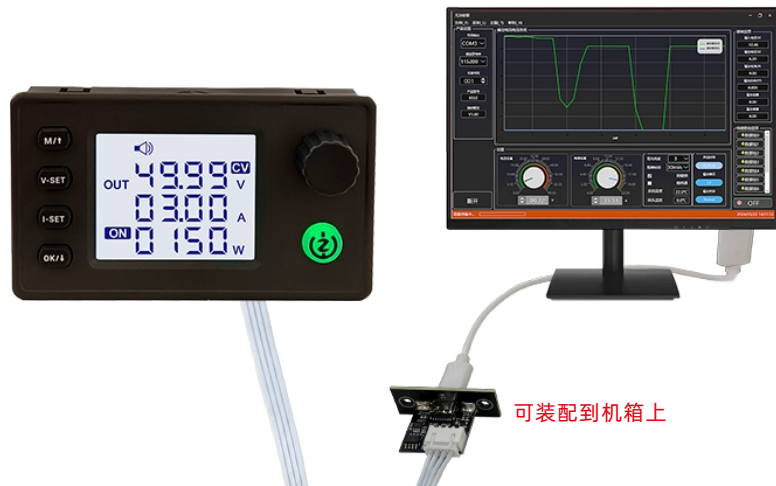

- ① 电脑插入数据线连接ZK-U2T (usb转ttl模块)，ZK-U2T模块另一端4P线插入电源主板的通信口；
- ② 在我的电脑-设备管理器-端口中找到USB-SERIAL CH340对应的端口号COMx；
- ③ 电脑打开“无治智联”上位机，选择对应的端口号COMx，点击上位机左下角的“连接”按钮，自动联机。
- ④ 运行环境是 .NET Framework 4.8 如果有运行不了的可至 .net官网下载安装



下载上位机

下面附Modbus通讯协议

一. 协议简介

采用 TTL 串口传输接口，通信协议为 MODBUS-RTU 协议，本产品只支持功能码 0x03、0x06、0x10。

二. 通信协议介绍

信息传输为异步方式，Modbus-RTU 模式以 11 位的字节为单位

起始位	1 位
数据位	8 位
奇偶校验位	无
停止位	1 位

数据帧结构:

数据帧间隔	地址码	功能码	数据区	CRC 校验
3.5 字节以上	1 字节	1 字节	N 字节	2 字节

发送数据前要求数据总线静止时间即无数据发送时间大于 3.5 (例如: 波特率为 9600 时为 5ms) 消息发送至少要以 3.5 个字节时间的停顿间隔开始, 整个消息帧必须作为一连 续的数据传输流, 如果在帧完成之前有超过 3.5 个字节时间的停顿时间, 接收设备将刷新 不完整的消息并假定下一字节是一个新消息的地址域。同样地, 如果一个新消息在小于 3.5 个字符时间内接着前个消息开始, 接收的设备将认为它是前一消息的延续。

1.1 地址码:

地址码是每次通讯信息帧的第一字节 (8 位), 从 1 到 255 (初始默认为 1, 0 同时也为广播地址)。这个字节表明由用户设置地址的从机将接收由主机发送来的信息。每个从机都必须有唯一的地址码, 并且只有符合地 址码的从机才能响应回送信息。当从机回送信息时, 回送数据均以各自的地址码开始。主机发送的地址码表明将发送到从机地址, 而从机返回的地址码表明回送的从机地址。相应的地址码表明该信息来自于何处。

1.2 功能码:

功能码为每次通讯信息帧传送的第二个字节, ModBus 通讯规约可定义的功能码为 1 到 127。作为主机请求发送, 通过功能码告诉从机应执行什么动作。作为从机响应, 从机返回 的功能码与从主机发送来的功能码一样, 并表明从机已响应主机并且已进行相关的操作。本机仅支持 0x03、0x06、0x10 功能码。

功能码	定义	操作 (二进制)
0x03	读寄存器数据	读取一个或多个寄存器的数据
0x06	写单个寄存器	把一组二进制数据写入单个寄存器
0x10	写多个寄存器	把多组二进制数据写入多个寄存器

1.3 数据区

数据区包括需要由从机返送何种信息或执行什么动作, 这些信息可以是数据 (如: 开 关量输入/输出、模拟量输入/输出、寄存器等等)、参考地址等。例如, 主机通过功能码 03 告诉从机返回寄存器的值 (包含要读取寄存器的起始地址及读取寄存器的长度), 则返回的数据包括寄存器的数据长度及数据内容。(单个寄存器地址内的数据为双字节型数据)

0x03 读取功能主机格式

地址码	功能码	寄存器起始地 址	寄存器地址数量 n(1~ 32)	CRC 校验码
1 字节	1 字节	2 字节	2 字节	2 字节
01	03	00 00	00 10	44 06

0x03 读取功能从机返回格式

地址码	功能码	返回寄存器个数 n	寄存器数据	CRC 校验码
1 字节	1 字节	1 字节	2*n 个字节	2 字节
01	03	04	2*n	

0x06 写单个寄存器功能主机格式

地址码	功能码	寄存器起始地 址	寄存器数据	CRC 校验码
1 字节	1 字节	2 字节	2 字节	2 字节
01	06	00 12	00 01	E8 0F

0x06 写单个寄存器功能从机返回格式

地址码	功能码	寄存器起始 地址	寄存器数据	CRC 校验码
1 字节	1 字节	2 字节	2 个字节	2 字节
01	06	00 12	00 01	E8 0F

0x10 写多个寄存器功能主机格式

地址码	功能码	寄存器起始 地址	寄存器地址数量 n(1~32)	写入字节数 2*n	寄存器数据 2*n 字节	CRC 校 验码 2 字节
1 字节	1 字节	2 字节	2 字节	1 字节	2*n 字节	2 字节

0x10 写多个寄存器从机主机格式

地址码	功能码	寄存器起始地址	寄存器地址数量 n(1~32)	CRC 校验码
1 字节	1 字节	2 字节	1 字节	2 字节

协议寄存器介绍 (单个寄存器地址内的数据为双字节型数据)

名称	说明	字节数	小数 点	单位	读写	寄存器地址
V-SET	电压设置	2	2	V	R/W	0000H
I-SET	电流设置	2	2	A	R/W	0001H
VOUT	输出电压显示值	2	2	V	R	0002H
IOUT	输出电流显示值	2	2	A	R	0003H
POWER	输出功率显示值	2	1	W	R	0004H
UIN	输入电压显示值	2	2	V	R	0005H
AH-LOW	输出 AH 低 16 位	2	0	maH	R	0006H
AH-HIGH	输出 AH 高 16 位	2	0	maH	R	0007H
WH-LOW	输出 WH 低 16 位	2	0	mwH	R	0008H
WH-HIGH	输出 WH 高 16 位	2	0	mwH	R	0009H
OUT_H	开启时长-小时	2	0	H	R	000AH
OUT_M	开始时长-分钟	2	0	M	R	000BH
OUT_S	开启时长-秒	2	0	S	R	000CH
T_IN	内部温度值	2	1	C	R	000DH
T_EX	外部温度值	2	1	C	R	000EH
LOCK	按键锁	2	0	-	R/W	000FH
PROTECT	保护状态	2	0	-	R/W	0010H

CVCC	恒压恒流状态	2	0	-	R	0011H
ONOFF	开关输出	2	0	-	R/W	0012H
F-C	温度符号	2	0	-	R	0013H
B-LED	背光亮度等级	2	0	-	R/W	0014H
SLEEP	息屏时间	2	0	M	R/W	0015H
MODEL	产品型号	2	0	-	R	0016H
VERSION	固件版本号	2	0	-	R	0017H
SLAVE-ADD	从机地址	2	0	-	R/W	0018H
BAUDRATE_L	波特率	2	0	-	R/W	0019H
T-IN-OFFSET	内部温度修正	2	1	C	R/W	001AH
T-EX-OFFSET	外部温度修正	2	1	C	R/W	001BH
BUZZER	蜂鸣器开关	2	0	-	R/W	001CH
EXTRACT-M	快捷调出数据组	2	0	-	R/W	001DH
DEVICE	设备状态	2	0	-	R/W	001EH
V-SET	电压设置	2	2	V	R/W	001FH
V-SET	电压设置	2	2	V	R/W	0050H
I-SET	电流设置	2	2	A	R/W	0051H
S-LVP	低压保护值	2	2	V	R/W	0052H
S-OVP	过压保护值	2	2	V	R/W	0053H
S-OCF	过流保护值	2	2	A	R/W	0054H
S-OPP	过功率保护值	2	1	W	R/W	0055H
S-OHP_H	最大输出时长一小时	2	0	H	R/W	0056H
S-OHP_M	最大输出时长一分钟	2	0	M	R/W	0057H
S-OAH_L	最大输出 AH 低 16 位	2	0	maH	R/W	0058H
S-OAH_H	最大输出 AH 高 16 位	2	0	maH	R/W	0059H
S-OWH_L	最大输出 WH 低 16 位	2	0	10mWH	R/W	005AH
S-OWH_H	最大输出 WH 高 16 位	2	0	10mWH	R/W	005BH
S-OTP	过温保护值	2	1	F/C	R/W	005CH
S-INI	上电输出开关	2	0	-	R/W	005DH
S-0_CLOSE	过时 过容量 过能量开关 最后一位 开关状态	2	0	-	R/W	005EH
	0000000000000001 过时					
	0000000000000010 过容					
	0000000000000100 过能					
	0000000100000000					
Restore Factory	恢复出厂设置	2	0	-	W	0020H
ZERO	清零	2	0	-	W	0021H
Reset	重启	2	0	-	W	002FH

注 1:本产品设有 M0-M10 共 11 组存储数据组, 每组有序号 00-0D 共 14 个数据, 其中 M0 数据组为产品上电默认调用的数据组, 数据组的起始地址计算方法是: 0050H+数据组号*0010H, 例如 M3 数据组的起始地址为:

0050H+3*0010H=0080H。

注 2:按键锁功能读写数值为 0 和 1, 0 为非锁定, 1 为锁定。

注 3:保护状态读取值为 0-11:

0:正常运行, 1:OVP, 2:OCP, 3:OPP, 4:LVP, 5:OAH, 6:OHP, 7:OTP, 8:OEP, 9:OWH, 10:ICP。 11: IVP

注 4:恒压恒流状态读取值为 0 和 1, 0 为 CV 状态, 1 为 CC 状态。

注 5:开关输出功能读写值为 0 和 1, 0 为关闭状态, 1 为打开状态。

注 6:背光亮度等级读写范围为 0-5, 0 级最暗, 5 级最亮。

注 7:快捷调出数据组功能写入值为 0-10, 写入后会自动调出对应数据组数据。

1.4 错误校验码 (CRC 校验):

主机或从机可用校验码进行判别接收信息是否正确。由于电子噪声或一些其它干扰, 信息在传输过程中有时会发生错误, 错误校验码 (CRC) 可以检验主机或从机在通讯数据传送过程中的信息是否有误, 错误的信息可以放弃 (无论是发送还是接收), 这样增加了系统的安全和效率。MODBUS 通讯协议的 CRC (冗余循环码) 包含 2 个字节, 即 16 位二进制数。CRC 码由发送设备 (主机) 计算, 放置于发送信息帧的尾部。接收信息的设备 (从机) 再重新计算接收到信息的 CRC, 比较计算得到的 CRC 是否与接收到的相符, 如果两者不相符, 则表明出错。CRC 校验码发送时低位在前, 高位在后。

CRC 码的计算方法:

- (1) 预置 1 个 16 位的寄存器为十六进制 FFFF (即全为 1); 称此寄存器为 CRC 寄存器;
- (2) 把第一个 8 位二进制数据 (既通讯信息帧的第一个字节) 与 16 位的 CRC 寄存器的低 8 位相异或, 把结果放于 CRC 寄存器;
- (3) 把 CRC 寄存器的内容右移一位 (朝低位) 用 0 填补最高位, 并检查右移后的移出位;
- (4) 如果移出位为 0: 重复第 3 步 (再次右移一位); 如果移出位为 1: CRC 寄存器与多项式 A001 (1010 0000 0000 0001) 进行异或;
- (5) 重复步骤 3 和 4, 直到右移 8 次, 这样整个 8 位数据全部进行了处理;
- (6) 重复步骤 2 到步骤 5, 进行通讯信息帧下一个字节的处理;
- (7) 将该通讯信息帧所有字节按上述步骤计算完成后, 得到的 16 位 CRC 寄存器的高、低字节进行交换;
- (8) 最后得到的 CRC 寄存器内容即为 CRC 码。

三、通讯实例

例 1: 主机读取输出电压和输出电流显示值

主机发送的报文格式:

主机发送	字节数	发送的信息	备注
从机地址	1	01	发送至地址为 01 的从机
功能码	1	03	读寄存器
寄存器起始地址	2	0002H	寄存器起始地址
寄存器地址数量	2	0002H	共 2 个字节
CRC 码	2	65CBH	由主机计算得到 CRC 码

例如如当前显示值是 05.00V, 2.00A, 则从机响应返回的报文格式:

从机响应	字节数	返回的信息	备注
从机地址	1	01	来自从机 01
功能码	1	03	读寄存器
读取字节数	1	04	共 1 个字节
地址为 0002H 寄存器的内容	2	01F4H	输出电压显示值
地址为 0003H 寄存器的内容	2	00C8H	输出电流显示值

CRC 码	2	BBABH	由从机计算得到 CRC 码
-------	---	-------	---------------

例 2：主机要设定电压为 12.00V

主机发送的报文格式：

主机发送	字节数	发送的信息	备注
从机地址	1	01H	来自从机 01
功能码	1	06H	写单个寄存器
寄存器地址	2	0000H	寄存器地址
地址为 0000H 寄存器的内容	2	04B0H	设定输出电压值
CRC 码	2	8ABEH	由主机计算得到 CRC 码

从机接收后响应返回的报文格式：

从机响应	字节数	返回的信息	备注
从机地址	1	01H	发送至地址为 01 的从机
功能码	1	06H	写单个寄存器
寄存器地址	2	0000H	寄存器起始地址
地址为 0000H 寄存器的内容	2	04B0H	设定输出电压值
CRC 码	2	8ABEH	由从机计算得到 CRC 码

例 3：主机要设定电压为 24.00V，电流 15.00A。

主机发送的报文格式：

主机发送	字节数	发送的信息	备注
从机地址	1	01H	来自从机 01
功能码	1	10H	写寄存器
寄存器起始地址	2	0000H	寄存器起始地址
寄存器地址数量	2	0002H	共 2 个字节
写入字节数	1	04H	共 1 个字节
地址为 0000H 寄存器的内容	2	0960H	设定输出电压值
地址为 0001H 寄存器的内容	2	05DCH	设定输出电流值
CRC 码	2	F2E4H	由主机计算得到 CRC 码

从机接收后响应返回的报文格式：

从机响应	字节数	返回的信息	备注
从机地址	1	01H	发送至地址为 01 的从机
功能码	1	10H	写寄存器
寄存器起始地址	2	0000H	寄存器起始地址
寄存器地址数量	2	0002H	共 2 个字节
CRC 码	2	41C8H	由从机计算得到 CRC 码

Third generation upgraded CNC voltage buck-boost power supply

Model: ZK-SK150Pro

Product parameters

Product name: CNC DC voltage buck-boost power supply	Product model: ZK-SK150Pro
Input voltage: 7-36.00V	Output voltage: 0.5-40.00V
Output current: 0-8.000A	Output voltage accuracy: $\pm 0.3\%+3$ words (Calibratable)
Output power: 150W	Output current accuracy: $\pm 0.5\%+3$ words (Calibratable)
Voltage resolution: 0.01V	Current resolution: 0.001A
Data group storage: 11 groups	Silicon rubber keypads: 5
Screen size: Upgraded 1.8-inch large screen, 36 * 29mm visible range	Buzzer: Yes
Conversion efficiency: About 88%	Soft start: Yes
Product size: 83x48x48mm. (Height does not include rotary encoder)	
Product weight: Net weight 112g, Weight with packaging 132g;	

Protection mechanism:

Input anti reverse connection: Yes
 Output anti backflow: Yes
 Input undervoltage protection (LUP): 6.0-40V adjustable, factory default value of 6.0V
 Output overvoltage protection (OUP): 0.5-42V adjustable, factory default value 42V
 Output overcurrent protection (OCP): 0.001-8.2A adjustable, factory default value 8.2A
 Output overpower protection (OPP): 0.1-180W adjustable, factory default value 160W
 Over temperature protection (OTP): 30-150 °C adjustable, factory default value of 100°C
 Timeout protection (OHP): 1-99 hours and 59 minutes, factory default off
 Overcapacity protection (OAH): 0.001-9999Ah, factory default off
 Superenergy protection (OPH): 0.001-4000KWh, factory default off

Key functions

Short press: Switching input voltage/output voltage display
Long press: Enter or exit the settings menu

Short press: Selection bit (setting menu interface)
Long press: Open/Unlock function
Left rotation: Number reduction
Right rotation: Number increase



Short press: Switching Output power W/ Capacity Ah/Energy Wh/Time h/ Temperature °C/Rotating display

Short press: Turn off/on output
Long press: Sleep shutdown

Display interface

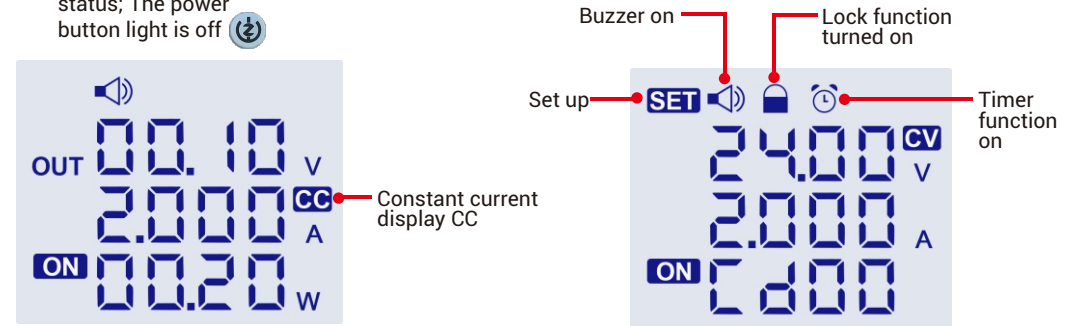
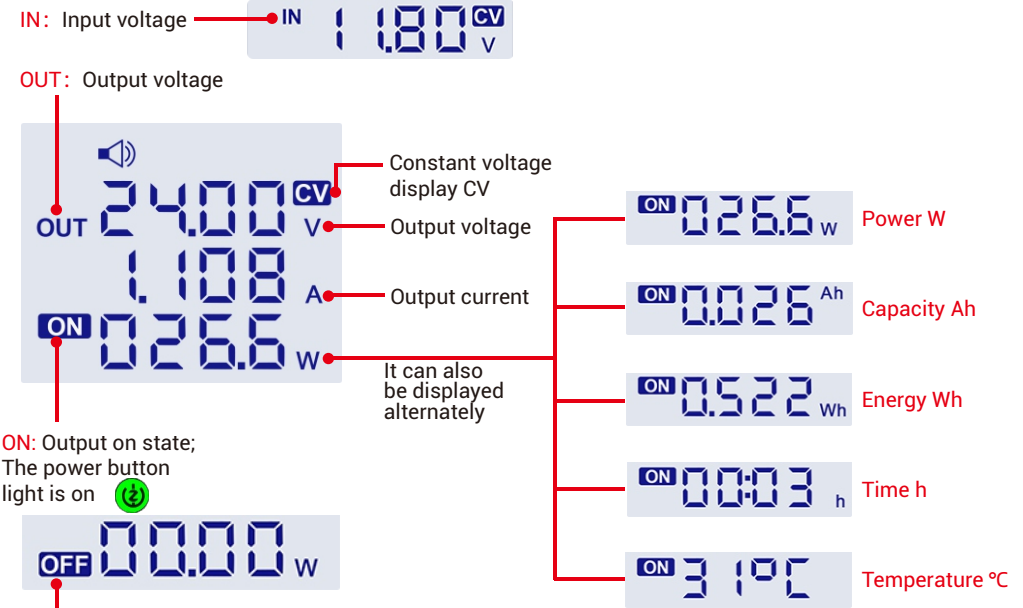

Product size



Suggested opening size

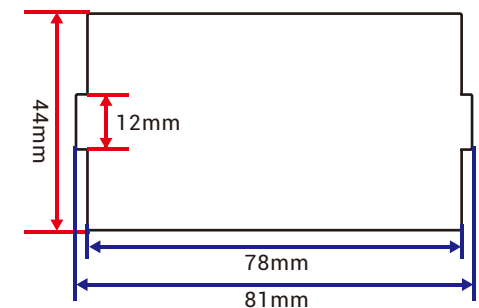

Instructions for use

Set voltage and current/call data group



Press **V-SET** to enter the voltage setting interface, adjust the flashing position, press the encoder to select the position, and rotate to adjust the size. After setting up, press **V-SET** again to exit the setup.

Press **OK/↓** to switch data groups Cd00-Cd10.



Press **I-SET** to enter the current setting interface, adjust the flashing position, press the encoder to select the position, and rotate to adjust the size. After setting up, press **I-SET** again to exit the setup.

Press **OK/↓** to switch data groups Cd00-Cd10.

Switching output/input voltage display



Press **M/↑** to switch between output voltage and input voltage display

Switching output power/capacity and other displays



Press **OK/↓** to switch output power W/capacity Ah/energy Wh/time h/temperature / rotating display

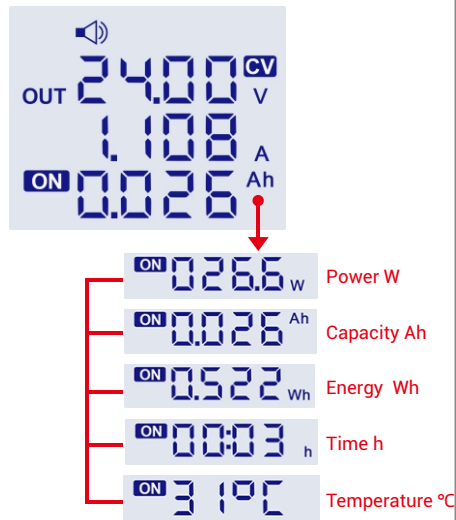

Locking function

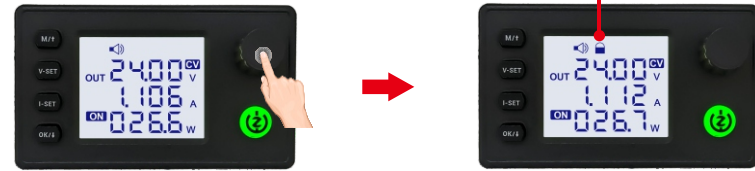

On the normal display interface, long press and hold the rotary encoder for 2 seconds to lock the set voltage and current to prevent accidental operation; After locking, press and hold the encoder for 2 seconds to unlock. After locking, the power button can still operate normally, ensuring that the power can be disconnected at any time.

Parameter settings

Press and hold **M/↑** for 2 seconds to enter the settings menu. The first interface is the OUT settings interface,

Press **V-SET** to switch data group names, press **I-SET** to select the previous parameter,

Press **OK/↓** to select the next parameter.

Parameter settings within the data group

OUP setting (Overvoltage protection)



Short press the encoder to select a bit and adjust the value size by rotating it.

For example, if OUP is set to 24.00, when the output voltage is greater than 24.00V, the output will turn off the protection, thereby protecting the load from being burnt out due to overvoltage power supply. After protection, the bottom row will display OUP. Press the power button to cancel the protection.

OCP setting (Overcurrent protection)



Short press the encoder to select a bit and adjust the value size by rotating it.

For example, if OCP is set to 2.000, when the output current is greater than 2.000A, the output will turn off the protection, thereby protecting the load from being burnt out due to overcurrent. After protection, the bottom row will display OCP. Press the power button to cancel the protection.

LUP setting (Undervoltage protection)



Short press the encoder to select a bit and adjust the value size by rotating it.

For example, if LUP is set to 10.00, the output will turn off protection when the input voltage is below 10.00V. After protection, the bottom row will display LUP. Press the power button to cancel the protection, or automatically cancel the protection when the input voltage is higher than LUP.

OPP setting (Overpower protection)



Short press the encoder to select a bit and adjust the value size by rotating it.

For example, if OPP is set to 30.00W, when the output power is higher than 30.00W, the output will turn off the protection, thereby protecting the load from being burnt out due to overpower. After protection, the bottom row will display OPP. Press the power button to cancel the protection.





OAH settings (Over capacity protection)







Short press the power button to turn on/off the over capacity protection function, "----" Turn off this function





After turning on this function by pressing the power button, short press the encoder to select the position, adjust the value size by rotation, and long press the power button to switch the decimal point position (0.000Ah, 00.00Ah, 000.0Ah, 0000Ah), can be set to a maximum of 9999Ah.

For example, if OAH is set to 1.000Ah, when the cumulative output capacity exceeds 1.000Ah, the output will turn off the protection. After protection, the bottom row will display OAH, press the power button to cancel protection, and the cumulative capacity will be reset to zero.

<p>OPH setting (Over energy protection)</p> 	<p>Short press the power button to turn on/off the over energy protection function,"----"Turn off this function</p> <p>After turning on this function by pressing the power button, short press the encoder to select the position and adjust the value by rotating it Size, long press the power button to switch the decimal point position [0.000Wh, 00.00Wh, 000.0Wh, 0000Wh, 0.0.0.0Wh (Representing 0000KWh)], with a maximum setting of 4000KWh.</p> <p>For example, if OPH is set to 100.0Wh, when the accumulated energy output exceeds 100.0Wh, the output will turn off the protection.</p> <p>After protection, the bottom row will display OPH, press the power button to cancel protection, and the accumulated energy will be reset to zero.</p>
<p>OHP setting (Over time protection)</p> 	<p>Short press the power button to turn on/off the timeout protection function,"----"Turn off this function</p> <p>After turning on this function by pressing the power button, short press the encoder to select the position, and adjust the value size by rotating it. The minimum unit is 1 minute, and the maximum can be set to 99 hours and 59 minutes.</p> <p>For example, if OHP is set to 02:30 and the startup time exceeds 2 hours and 30 minutes, the output will turn off the protection.</p> <p>After protection, the bottom line will display OHP, press the power button to cancel protection, and the startup time will be reset to zero.</p>
<p>OTP setting (Over temperature protection)</p> 	<p>Short press the encoder to select a bit, adjust the value size by rotation, unit: °C</p> <p>For example, if OTP is set to 90°C, when the PCB temperature near the power transistor reaches 90°C, the output will turn off the protection.</p> <p>After protection, the bottom row will display OTP. Press the power button to cancel the protection.</p>
<p>PON setting (Default power on output)</p> 	<p>Short press the power button and select the output to turn off/on after power on</p> <p>For example, if PON is set to OFF, the output of the module will be turned off every time it is first powered on, and the power button needs to be pressed to turn on the output; Otherwise, the output of the module will be directly turned on after being powered on.</p>

System parameter setting

<p>Add settings (Address)</p> 	<p>Short press the encoder to select a bit and adjust the value size by rotating it</p> <p>Address range 001-255</p>
<p>LEd setting (Backlight brightness)</p> 	<p>Adjust the numerical value by rotating it, Level 0-5, where 0 completely turns off the backlight.</p> <p>The factory default is level 5 brightest.</p>
<p>SLP setting (Automatic screen shutdown)</p> 	<p>Short press the power button to turn on/off the screen without any operation (only turn off backlight) function,"----"Turn off this function</p> <p>After turning on this function by pressing the power button, short press the encoder to select the position, and adjust the value by rotating it for 1-60 minutes.</p> <p>For example, if SLP is set to 01, the screen will automatically turn off when there is no operation for more than 1 minute.</p>
<p>bEEP setting (Buzzer enabled)</p> 	<p>Short press the power button to turn on/off the buzzer</p> <p>For example, if the display is OFF, the buzzer will be turned off and there will be no more buttons or alarm prompts.</p>

<p>Zero setting (Current zero calibration)</p> 	<p>If there is a small current of less than 200mA when the output is not connected to the load, you can short press the power button to calibrate the zero point.</p> <p>When calibrating the zero point, do not connect the output end to the load.</p>
<p>Frd setting (Restore factory settings)</p> 	<p>You can press and hold the power button, and Frd will not flash to restore the factory default.</p>
<p>CAL_U setting (Calibration output voltage)</p> 	<p>If the output voltage is not accurate, the output voltage can be calibrated.</p> <ol style="list-style-type: none"> Short press the power button, the second line displays step 01, the first line displays voltage with flashing numbers, and short press the rotary encoder to shift. Use a multimeter to measure the actual voltage at the current output terminal (output terminal unloaded, measure the power terminal) and input it to the first row. Short press the power button, and the second line displays step 02. Use a multimeter to measure the actual voltage at the current output terminal again and input it to the first row. Short press the power button to complete the calibration. <p>If calibration is successful, the second line displays SUC, otherwise it displays Err. If it fails, you can try calibrating again.</p>
<p>CAL_I setting (Calibration output current)</p> 	<p>If the output current is not accurate, the output current can be calibrated.</p> <ol style="list-style-type: none"> Short press the power button, the first line displays step 01, the second line displays a flashing current number, and short press the rotary encoder to shift. Use a multimeter or electronic load to short circuit the output terminals and measure the current actual current, then input it to the second line. Short press the power button, and the first line displays step 02. Use a multimeter to measure the actual current output again and input it to the second row. Short press the power button to complete the calibration. <p>If calibration is successful, the second line displays SUC, otherwise it displays Err. If it fails, you can try calibrating again.</p>

APP online method



- ① Insert the communication interface of the power motherboard into the ZK-BT BT board, and the ZK-BT indicator light will flash once when inserted.
- ② Open the Wuzhi Zhilian APP and mobile BT, click "Add Device" on the APP interface, and Wuzhi Power will be automatically searched for. After clicking, it will automatically connect.
- ③ Display successful connection, click complete.
- ④ Click on the device icon to enter the normal operation interface. Long press the product icon to change the name or delete the device.



Download the power app

Online method of upper computer

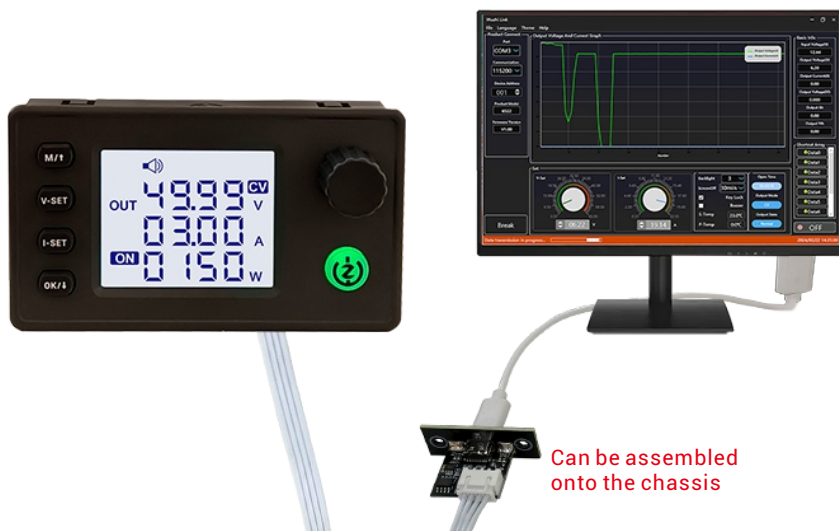

Can be assembled
onto the chassis

- ① Insert a data cable into the computer and connect it to the ZK-U2T (USB to TTL module). The other end of the ZK-U2T module has a 4P cable inserted into the communication port of the power motherboard;
- ② Find the port number COMx corresponding to USB-Serial CH340 in my computer - Device Manager - Ports;
- ③ Open the "Wuzhi Zhilian" upper computer, select the corresponding port number COMx, and click the "Connect" button in the bottom left corner of the upper computer to automatically connect.
- ④ The operating environment is If NET Framework 4.8 cannot run, you can download and install it from the .net official website



Download the upper computer

Attached below is the Modbus communication protocol

一. Protocol Introduction

Using TTL serial transmission interface and MODBUS-RTU communication protocol, this product only supports function codes 0x03, 0x06, and 0x10.

2、 Introduction to Communication Protocol:

Information transmission is asynchronous, and Modbus RTU mode is based on 11 bit bytes

Starting position	1 digit
Data bits	8 digits
Parity check bit	nothing
Stop bit	1 digit

Data frame structure:

Data frame interval	Address code	Function code	Data area	CRC verification
3.5 bytes or more	1 byte	1 byte	N bytes	2 bytes

Before sending data, it is required that the data bus rest time, i.e. no data transmission time, be greater than 3.5 (for example, 5ms at a baud rate of 9600). Message transmission must start with a pause interval of at least 3.5 bytes, and the entire message frame must be treated as a continuous data transmission stream. If there is a pause time of more than 3.5 bytes before the frame is completed, the receiving device will refresh the incomplete message and assume that the next byte is the address domain of a new message. Similarly, if a new message starts with the previous message within less than 3.5 characters, the receiving device will consider it a continuation of the previous message.

1. 1 Address Code:

The address code is the first byte (8 bits) of each communication information frame, ranging from 1 to 255 (initially set to 1,0 and also the broadcast address). This byte indicates that the slave set by the user will receive information sent by the host. Each slave must have a unique address code, and only slaves that match the address code can respond to feedback messages. When the slave sends back information, the returned data starts with their respective address codes. The address code sent by the host indicates the slave address to be sent, while the address code returned by the slave indicates the slave address to be returned. The corresponding address code indicates where the information comes from.

1. 2 Function code:

The function code is the second byte transmitted in each communication information frame, and the ModBus communication protocol can define function codes ranging from 1 to 127. Sent as a host request, telling the slave what action to take through a function code. As a response from the slave, the function code returned by the slave is the same as the function code sent from the master, and indicates that the slave has responded to the master and performed relevant operations. This machine only supports function codes 0x03, 0x06, and 0x10.

Function code	Definition	Operation (binary)
0x03	Read register data	Read data from one or more registers
0x06	Write a single register	Write a set of binary data into a single register
0x10	Write multiple registers	Write multiple sets of binary data into multiple registers

1. 3 Data Area

The data area includes what information or actions need to be returned by the slave, which can be

data (such as switch inputs/outputs, analog inputs/outputs, registers, etc.), reference addresses, etc. For example, if the host tells the slave through function code 03 to return the value of the register (including the starting address of the register to be read and the length of the read register), the returned data includes the length and content of the register. (The data within a single register address is double byte data)

0x03 Read function host format

Address code	Function code	Register Start Address	Number of register addresses n (1-32)	CRC verification code
1 byte	1 byte	2 bytes	2 bytes	2 bytes
01	03	00 00	00 10	44 06

0x03 Read Function Slave Return Format

Address code	Function code	Return the number of registers n	Register data	CRC verification code
1 byte	1 byte	1 byte	2*n 个字节	2 bytes
01	03	04	2*n	

0x06 Write Single Register Function Host Format

Address code	Function code	Register Start Address	Register data	CRC verification code
1 byte	1 byte	2 bytes	2 bytes	2 bytes
01	06	00 12	00 01	E8 0F

0x06 Write Single Register Function Slave Return Format

Address code	Function code	Register Start Address	Register data	CRC verification code
1 byte	1 byte	2 bytes	2 bytes	2 bytes
01	06	00 12	00 01	E8 0F

0x10 Write Multiple Registers Function Host Format

Address code	Function code	Register Start Address	Number of register addresses n (1-32)	Write Bytes 2*n	Register data	CRC verification code
1 byte	1 byte	2 bytes	2 bytes	1 byte	2*n 字节	2 bytes

0x10 Write multiple registers in slave host format

Address code	Function code	Register Start Address	Number of register addresses n (1-32)	CRC verification code
1 byte	1 byte	2 bytes	1 byte	2 bytes

Introduction to Protocol Registers (Data within a Single Register Address is Double Byte Data)

name	explain	Byte count	decimal point	unit	Reading and	Register Address
------	---------	------------	---------------	------	-------------	------------------

					writing	
V-SET	Voltage setting	2	2	V	R/W	0000H
I-SET	Current setting	2	2	A	R/W	0001H
VOUT	Output voltage display value	2	2	V	R	0002H
IOUT	Output current display value	2	2	A	R	0003H
POWER	Output power display value	2	1	W	R	0004H
UIN	Input voltage display value	2	2	V	R	0005H
AH-LOW	Output AH low 16 bits	2	0	maH	R	0006H
AH-HIGH	Output AH high 16 bits	2	0	maH	R	0007H
WH-LOW	Output WH low 16 bits	2	0	mwH	R	0008H
WH-HIGH	Output WH high 16 bits	2	0	mwH	R	0009H
OUT-H	Opening duration - hours	2	0	H	R	000AH
OUT-M	Start time in minutes	2	0	M	R	000BH
OUT-S	Opening time - seconds	2	0	S	R	000CH
T. IN	Internal temperature value	2	1	C	R	000DH
T. EX	External temperature value	2	1	C	R	000EH
LOCK	Key lock	2	0	-	R/W	000FH
PROTECT	Protection status	2	0	-	R/W	0010H
CVCC	Constant voltage and constant current state	2	0	-	R	0011H
ONOFF	Switch output	2	0	-	R/W	0012H
F-C	Temperature symbol	2	0	-	R	0013H
B-LED	Backlight brightness level	2	0	-	R/W	0014H
SLEEP	Screen rest time	2	0	M	R/W	0015H
MODEL	Product model	2	0	-	R	0016H
VERSION	Firmware Version	2	0	-	R	0017H
SLAVE-ADD	Slave address	2	0	-	R/W	0018H
BAUDRATE-L	Baud rate	2	0	-	R/W	0019H
T-IN-OFFSET	Internal temperature correction	2	1	C	R/W	001AH
T-EX-OFFSET	External temperature correction	2	1	C	R/W	001BH
BUZZER	Buzzer switch	2	0	-	R/W	001CH
EXTRACT-M	Quick access to data groups	2	0	-	R/W	001DH
DEVICE	Device status	2	0	-	R/W	001EH
V-SET	Voltage setting	2	2	V	R/W	001FH
V-SET	Voltage setting	2	2	V	R/W	0050H
I-SET	Current setting	2	2	A	R/W	0051H

S-LVP	Low voltage protection value	2	2	V	R/W	0052H
S-OVP	Overvoltage protection value	2	2	V	R/W	0053H
S-OCV	Overcurrent protection value	2	2	A	R/W	0054H
S-OPP	Overpower protection value	2	1	W	R/W	0055H
S-OHP_H	Maximum output duration - hours	2	0	H	R/W	0056H
S-OHP_M	Maximum output duration in minutes	2	0	M	R/W	0057H
S-OAH.L	Maximum output AH low 16 bits	2	0	maH	R/W	0058H
S-OAH.H	Maximum output AH high 16 bits	2	0	maH	R/W	0059H
S-OWH.L	Maximum output WH low 16 bits	2	0	10mwH	R/W	005AH
S-OWH.H	Maximum output WH high 16 bits	2	0	10mwH	R/W	005BH
S-OTP	Over temperature protection value	2	1	F/C	R/W	005CH
S-INI	Power on output switch	2	0	-	R/W	005DH
S-O-CLOSE	The last switch state of the outdated over capacity and over energy switch Obsolete Over capacity 10000000000000 100 Overpower 000000 10000000	2	0	-	R/W	005EH
Restore Factory	Restore factory settings	2	0		W	0020H
ZERO	Zeroing	2	0	-	W	0021H
Reset	restart	2	0		W	002FH

Note 1: This product is designed with 11 storage data groups of M0-M10, each with a total of 14 data groups numbered 00-0D. The M0 data group is the default data group called by the product when powered on, and the starting address calculation method for the data group is: 0050H+data group number * 0010H. For example, the starting address for the M3 data group is 0050H+3 * 0010H=0080H.

Note 2: The reading and writing values for the key lock function are 0 and 1, where 0 is non locked and 1 is locked.

Note 3: The read value for protection status is 0-11:

0: Normal operation, 1: OVP, 2: OCP, 3: OPP, 4: LVP, 5: OAH, 6: OHP, 7: OTP, 8: OEP, 9: OWH, 10: ICP.

11: IVP

Note 4: The reading values for constant voltage and current state are 0 and 1, where 0 is the CV state and 1 is the CC state.

Note 5: The read and write values for the switch output function are 0 and 1, with 0 being the off state and 1 being the on state.

Note 6: The reading and writing range of the backlight brightness level is 0-5, with level 0 being the darkest and level 5 being the brightest.

Note 7: The quick access data group function writes values from 0 to 10, and after writing, the corresponding data group data will be automatically retrieved.

1.4 Error Check Code (CRC Check):

The host or slave can use a checksum to determine whether the received information is correct. Due to electronic noise or other interferences, errors may sometimes occur during the transmission of information. Error check codes (CRC) can verify whether the information of the host or slave during communication data transmission is correct. Incorrect data can be discarded (whether sent or received), which increases the security and efficiency of the system. The CRC (Redundant Cyclic Code) of MODBUS communication protocol contains 2 bytes, which is a 16 bit binary number. The CRC code is calculated by the transmitting device (host) and placed at the end of the transmitted information frame. The receiving device (slave) recalculates the CRC of the received information and compares whether the calculated CRC matches the received CRC. If the two do not match, it indicates an error. When sending CRC checksum, the low bit is in front and the high bit is in the back.

Calculation method for CRC code:

- (1) Set one 16 bit register as hexadecimal FFFF (i.e. all are 1); Call this register CRC register;
- (2) Distinguish the first 8-bit binary data (i.e. the first byte of the communication information frame) from the lower 8 bits of the 16 bit CRC register, and place the result in the CRC register;
- (3) Shift the content of the CRC register to the right by one bit (towards the low bit) and fill the highest bit with 0, and check the shifted out bit after the right shift;
- (4) If the displacement is 0: repeat step 3 (move one position to the right again); If the removal bit is 1: CRC register XOR with polynomial A001 (1010 0000 0000 0001);
- (5) Repeat steps 3 and 4 until shifted 8 times to the right, so that the entire 8-bit data has been processed;
- (6) Repeat steps 2 to 5 to process the next byte of the communication information frame;
- (7) After calculating all bytes of the communication information frame according to the above steps, swap the high and low bytes of the 16 bit CRC register obtained;
- (8) The final CRC register obtained is the CRC code.

3、Communication

Example 1: The host reads the displayed values of output voltage and output current

Message format sent by the host:

Host sending	Byte count	Message sent	Remarks
Slave address	1	01	Sent to slave with address 01
Function code	1	03	Read Register
Register Start Address	2	0002H	Register Start Address
Number of register addresses	2	0002H	2 bytes in total
CRC code	2	65CBH	CRC code calculated by the host

For example, if the current displayed value is 05.00V, 2.00A, the format of the message returned by the slave response is:

Slave response	Byte count	Information returned	Remarks
Slave address	1	01	From slave 01
Function code	1	03	Read Register
Read Bytes	1	04	1 byte in total
The content of register with address 0002H	2	01F4H	Output voltage display value
The content of register with address 0003H	2	00C8H	Output current display value
CRC code	2	BBABH	CRC code calculated by slave machine

Example 2: The host needs to set the voltage to 12.00V

Message format sent by the host:

Host sending	Byte count	Message sent	Remarks
Slave address	1	01H	From slave 01
Function code	1	06H	Write a single register
Register Address	2	0000H	Register Address
The content of register with address 0000H	2	04B0H	Set output voltage value
CRC code	2	8ABEH	CRC code calculated by the host

The format of the message returned by the response received by the slave is:

Slave response	Byte count	Information returned	Remarks
Slave address	1	01H	Sent to slave with address 01
Function code	1	06H	Write a single register
Register Address	2	0000H	Register Start Address
The content of register with address 0000H	2	04B0H	Set output voltage value
CRC code	2	8ABEH	CRC code calculated by slave machine

Example 3: The host needs to set the voltage to 24.00V and the current to 15.00A.

Message format sent by the host:

Host sending	Byte count	Message sent	Remarks
Slave address	1	01H	From slave 01
Function code	1	10H	Write Register
Register Start Address	2	0000H	Register Start Address
Number of register addresses	2	0002H	2 bytes in total
Write Bytes	1	04H	1 byte in total
The content of register with address 0000H	2	0960H	Set output voltage value
The content of register 0001H with address	2	05DCH	Set output current value

CRC code	2	F2E4H	CRC code calculated by the host
----------	---	-------	---------------------------------

The format of the message returned by the response received by the slave is:

Slave response	Byte count	Information returned	Remarks
Slave address	1	01H	Sent to slave with address 01
Function code	1	10H	Write Register
Register Start Address	2	0000H	Register Start Address
Number of register addresses	2	0002H	2 bytes in total
CRC code	2	41C8H	CRC code calculated by slave machine